

BTI

THE NEW BELT CONVEYOR FOR THE GRAIN INDUSTRY



**SKANDIA
ELEVATOR**

THE LEADING COMPANY

BTI THE NEW BELT CONVEYOR FOR THE GRAIN INDUSTRY

**HAVE WE DEVELOPED
THE WORLD'S BEST
BELT CONVEYOR?**

PROBABLY.

BY ASKING THE PEOPLE WHO USE BELT CONVEYORS ON A DAILY BASIS, WE HAVE FOUND OUT WHAT THE MARKET DEMANDS AND NEEDS. THE RESULT IS AN INCREDIBLY WELL-DEVELOPED PRODUCT. WITH SKANDIA ELEVATOR'S SMART DESIGN AS A SIGNATURE, BTI IS BETTER, MORE EFFICIENT AND EASIER TO HANDLE THAN OTHER BELT CONVEYORS.



Discharge tripper



BTI THE NEW BELT CONVEYOR FOR THE GRAIN INDUSTRY

BETTER CONVEYING

Both belt width as well as idler and drum width are ISO-standardised and are set according to best practice in relation to capacity. The grain has plenty of space and the belt has good lateral travel. Naturally, the speed of the belt is also set according to best practice, and in addition, conveyors that are 20 metres long or more are equipped with tracking idler sets that ensure the belt control is improved on the return section. In addition, the centred loader is sealed with a PUR strip. In other words, no spill and more stable conveying of the grain.

SIMPLER ADJUSTMENT

The tail end has generous adjustment travel which reduces the need to re-vulcanise the belt after a period of stretching. In addition, the idler width makes the conveyor less sensitive to precision in the vulcanisation itself. The carrying idler sets centre the belt by means of offset alignment and the position of both carrying idlers can be adjusted individually for more precise belt travel settings and to adjust the offset alignment for reversible operation.

SIMPLE ASSEMBLY

As always, we have made sure that the assembly is simple and smooth. Just like all Skandia Elevator products, BTI is part of a modular system. This facilitates assembly and adaptation thanks to controlled processes and good fit. The simple assembly, along with our production engineering, helps to create a straighter and more stable machine from the very start, something that has been in strong demand from the market.

FLEXIBLE

BTI is designed for all conceivable environments and installations, both outdoors and indoors. The self-supporting length is up to 6 metres. BTI is available in three different models and each model has two different capacities. So regardless of the size, each installation can have a belt conveyor that fits perfectly and does not consume more energy than necessary.

UNEQUALLED QUALITY

Skandia Elevator never compromises on quality. Only the best materials and components are used. This leads to more reliable operation, increased service life and lower repair costs.



Drive end



Tracking idler set



Tail end



Loading unit

BTI THE NEW BELT CONVEYOR FOR THE GRAIN INDUSTRY

TAKE A CLOSER LOOK AT BTI

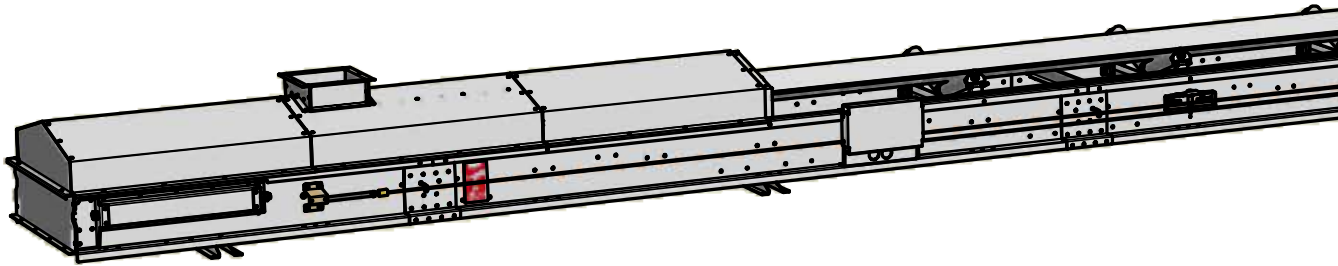

| | BTI 400 | | | BTI 500 | | | BTI 650 | | |
|------------|---------|------------|--------|------------|------------|--------|------------|--------|--------|
| L (m) | 0-30 | 31-63 | 64-100 | 0-24 | 25-57 | 58-100 | 0-13 | 14-51 | 52-100 |
| A (mm) | 1500 | 2 000 | 3000 | 1500 | 2 000 | 3000 | 1500 | 2 000 | 3000 |
| B (mm) | 1200 | 1 700 | 2700 | 1200 | 1 700 | 2700 | 1200 | 1 700 | 2700 |
| C (mm) | □ 180 | | | □ 250 | | | □ 300 | | |
| D (mm) | 1130 | | | 1270 | | | 1400 | | |
| E (mm) | 1130 | | | 1360 | | | 1570 | | |
| | 1,5 kW | 2,2-4,0 kW | | 1,5-2,2 kW | 3,0-5,5 kW | | 1,5-5,5 kW | 7,5 kW | |
| F Min. (m) | 7 | 9 | | 7 | 8 | | 8,5 | 9,5 | |
| G Min. (m) | 1,8 | | | 1,8 | | | 1,8 | | |

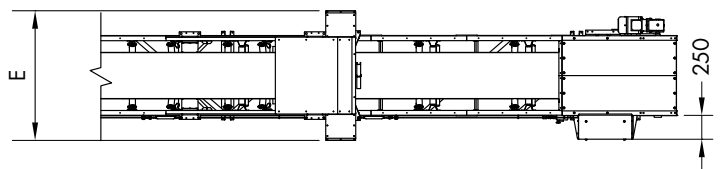
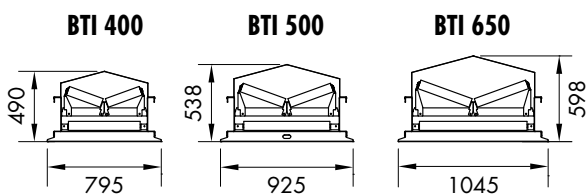
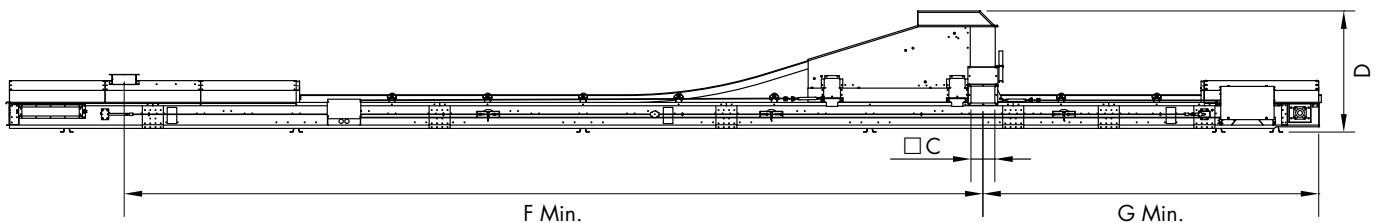
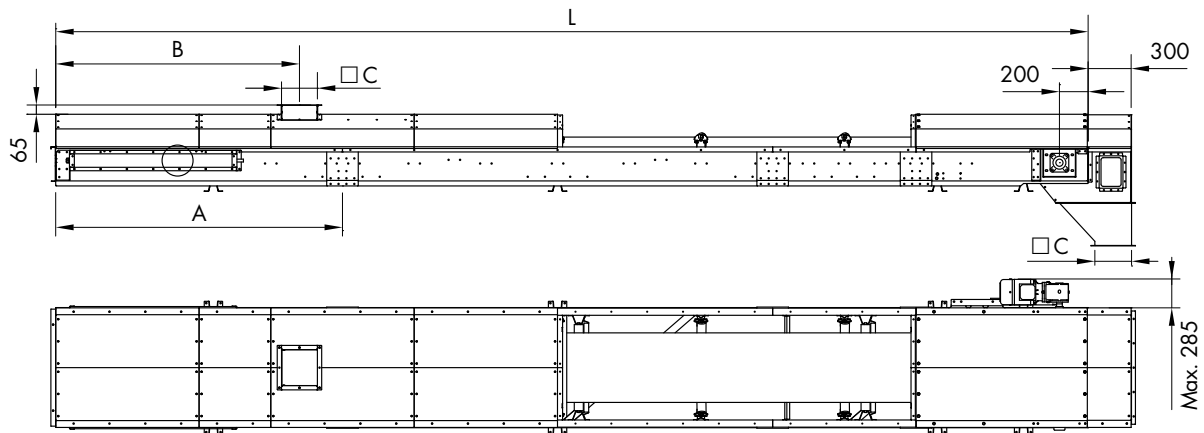

All drawings are available in CAD format.

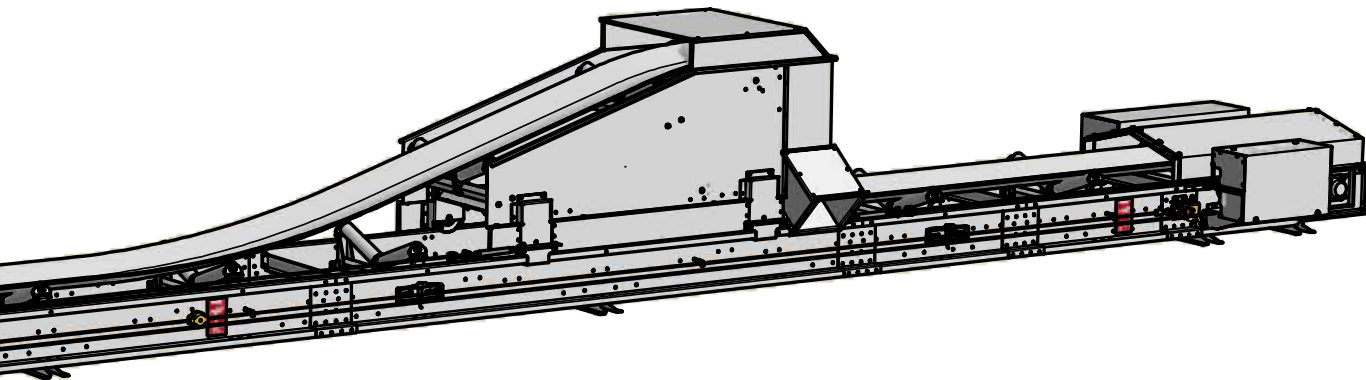

STANDARD EQUIPMENT:

- Drive end with adjustable drive pulley rubberised for motors greater than 3 kW, speed monitor on snub idler and cover.
- Bevel gear unit motor.
- Tail end with tensioning screws or counterweight tension for long conveyors (steel cable and counterweight not included), adjustable tail pulley, plough scraper and cover.
- Antistatic conveyor belt.
- Adjustable carrying idler set and return idler set.
- Adjustable tracking idler set for the return section, included at machine length ≥ 20 metres and then one more for every additional 20 metres.
- Permanently lubricated carrying idlers/return idlers/tracking idlers.
- Support feet.

ACCESSORIES:

- Loading unit with slider bed, skirting strips, gable, cover and inlet flange.
- Discharge tripper electric motor driven (steel cable purchased separately), inductive limit switches (2 pcs) and a 2-way valve (manual or electric motor driven).
- Steel cable for driving discharge tripper.
- Limit switch (for extra stop).
- Enclosure for end outlet with outlet hopper.
- Diagonal brace (extra for outdoor assembly) one for every 3 metres of conveyor.
- Oil resistant conveyor belt.
- Cable operated emergency stop.
- Cover.

| BTI BELT CONVEYOR | | BTI 400 | | BTI 500 | | BTI 650 | |
|---|-------------------|-----------------|-----------|-----------|-----------|-----------|-----------|
| | | 40 t/h | 60 t/h | 80 t/h | 100 t/h | 120 t/h | 150 t/h |
| Capacity for 750 kg/m ³ | t/h | 43–47 | 65–67 | 85–94 | 108–112 | 128–141 | 153–169 |
| Capacity | m ³ /h | 57–63 | 87–89 | 113–125 | 144–149 | 171–188 | 204–225 |
| Speed | rpm | 126–149 | 194–209 | 161–178 | 194–209 | 126–149 | 161–178 |
| Belt speed | m/s | 1.56–1.72 | 2.36–2.44 | 1.86–2.06 | 2.36–2.44 | 1.56–1.72 | 1.86–2.06 |
| Belt width | mm | 400 | | 500 | | 650 | |
| Self supporting length | m | 6 | | | | | |
| Belt type | | EP250/2 3+1,5 Y | | | | | |
| Connection loading unit/outlet hopper/ two-way valve discharge tripper | mm | □ 180 | | □ 250 | | □ 300 | |
| ATEX class (standard equipment) | | II OD/OD * | | | | | |

**Higher class as option at extra cost.*



**SKANDIA
ELEVATOR**

THE LEADING COMPANY